



CUPERTINO SANITARY DISTRICT

LEGEND:

- ① FOR SANITARY SEWER PIPE, USE CLASS 1 BEDDDING 12" ABOVE, 6" ON EACH SIDE AND 6" BELOW THE PIPE (3/4" CRUSHED ROCK).
- ② IMPORTED CLASS 2 AGGREGATE BASE 3/4" MAX OR NATIVE BACKFILL MATERIAL IF APPROVED BY THE DISTRICT ENGINEER. COMPACTED TO 95% RC OR 1-SACK SLURRY MIX IF REQUIRED BY THE LOCAL AGENCY OR DISTRICT ENGINEER.
- ③ CLASS 2 AGGREGATE BASE, 3/4" MAX.
- ④ 4" ASPHALT CONCRETE OR MATCH EXISTING DEPTH WHICHEVER IS GREATER.
- ⑤ APPLY TACK COAT ON SAW CUT EDGES PER SECTION 94 OF STATE SPECIFICATIONS.
- ⑥ TOPSOIL- MATCH EXISTING
- ⑦ GROUND COVER- MATCH EXISTING

NOTES:

1. RELATIVE COMPACTION (RC) SHALL MEAN COMPACTION AS DETERMINED BY CALIFORNIA COMPACTION TEST METHOD OR BY ASTM METHODS.
2. ASPHALT CONCRETE TO BE CLASS "B" 1/2" MAX AGGREGATE PER SECTION 39 OF STATE STANDARD SPECIFICATIONS.
3. ALL BACKFILL SHALL BE PLACED AND COMPACTED IN 6" MAXIMUM LIFTS.
4. CLASS 1 BEDDING AND CLASS 2 AGGREGATE BASE PER SECTION 26 OF THE STATE STANDARD SPECIFICATIONS.
5. EXISTING AC PAVEMENT SHALL BE REPLACED TO THE EDGE OF PAVEMENT WHEN THE EDGE OF THE TRENCH IS 2' OR LESS FROM THE EDGE OF PAVEMENT.
6. WIDTH OF THE OPEN TRENCH WHEN INSTALLING THE MAIN LINE SHALL TYPICALLY BE NO GREATER THAN 24".
7. THIS DETAIL DESCRIBES THE MINIMUM REQUIREMENTS FOR CUPERTINO SANITARY DISTRICT ONLY. ALL LOCAL AND COUNTY STANDARD SPECIFICATIONS MUST ALSO BE MET.

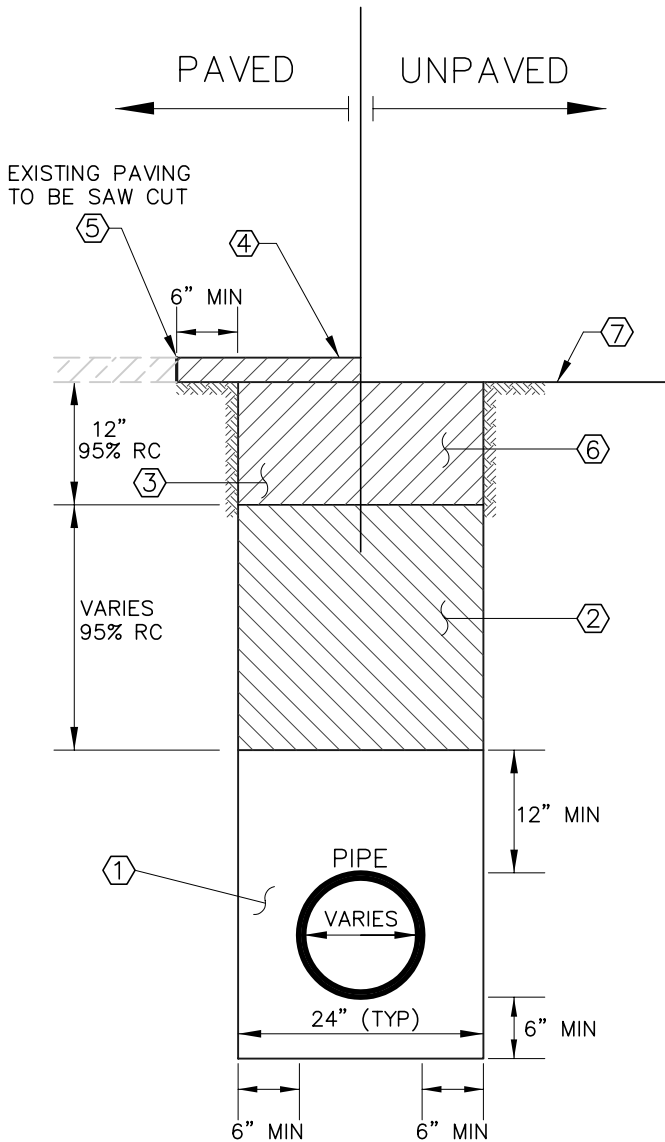

FILE NO.
SP-248

STANDARD TRENCH

DETAIL K

DR. BY: HJP DATE: 05/13/03

CK. BY: DMT DATE: 05/14/03

APPROVED. BY:

DATE: 5-15-03